

# Model DDP Belt Filter Press

## Designed for Small Plants

[www.bdpindustries.com](http://www.bdpindustries.com)



**Industry Leader in Design and Manufacture of Filtration Equipment**

# Big performance in a small package.

## Model DDP Belt Filter Press

**Model DDP Belt Press** was developed with the smaller size WWTP in mind. Whether the WWTP requires sludge dewatering capabilities for a few hours every other week, or for a few days per week, the DDP is the belt press of choice. The DDP is a 3-belt design belt press that will provide higher performance and flexibility over the competition.



### Design Features

**Feed Distributor:** Up-flow, over-flow weir configuration provides full belt-width distribution and uniform thickness.

**Independent Gravity Zone:** Gravity zone with belt drive speed control independent from the pressure zone. Allows for higher flow rate capacity and cake solids.

**Spiral Wedge:** Applies increasing cake pressure over the entire length in order to effectively express filtrate while maintaining excellent cake retention.

**Vertical Pressure Zone:** Vertical arrangement allows for filtrate pans under each roll to eliminate re-absorption of filtrate, improving discharge cake solids. Standard design is 4 rolls, including initial perforated roll.

**Overall Layout:** Gravity zone and controls located at operator level. Simplifies process optimization and eliminates platforms.

**Stainless Steel Bearings:** Dodge EZ Klean stainless steel ball bearing with plastic housing eliminates corrosion and provides long life.

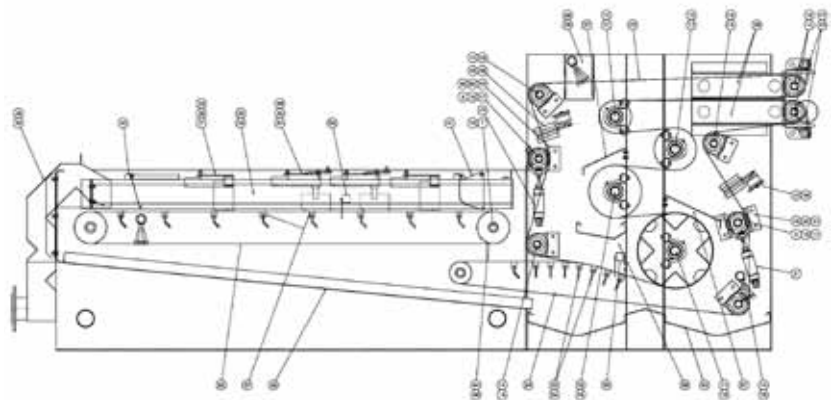

**Stainless Steel Roll Construction:** Roll shell, end plates and shafts are constructed of stainless steel; which allows for ridged low deflection rolls and eliminates corrosion.

**Stainless Steel Plate Frame:** Construction is from stainless steel plate, precision crafted using water jet technology. Large pipe cross bracing provides strong rigid frame support and eliminates corrosion.

# Unique Features and How They Work

BDP uses a three belt design to increase performance. Standard single belt or two belt technology employed by most manufacturers forces a compromise in either throughput capacity or discharge cake solid concentration, because belt speed for the two zones must be the same. Three belt technology used by BDP overcomes this limitation by allowing independent speed control in each zone.

In addition, significant improvements in feed distribution, the wedge zone, gradual pressure gradation, and the elimination of pooling and re-wetting in the pressure zone **MAXIMIZES PERFORMANCE.**

The unique low profile gravity zone, stainless steel plate frame, and stainless steel bearings provide ease of access and low maintenance cost.

**Up-flow feed box:** Slurry enters the feed box at floor level and then flows up and over the outlet weir. This spreads the slurry out very uniformly across the full belt width.

**Spiral Wedge:** The problem with most wedge layouts is the top belt doesn't apply pressure to the cake until 2/3 of the way through the zone. The support bars of the model DDP are fabricated in a spiral curve layout that forces the top and bottom belts together placing pressure on the cake throughout the entire zone. The support bars also function as cross supports for the frame.



Spiral Wedge

**Vertical Pressure Zone:** As with the model 3DP, the rolls in the pressure zone are arranged in a vertical configuration so that filtrate expressed at each roll drips from the tangent point into a diversion pan; eliminating rewetting of the cake. The first roll is perforated to enhance expression of filtrate.



Vertical Pressure Zone



Proportional Tracking

## Stainless Steel Plate

**Frame:** The frame is constructed from stainless steel plate, precision crafted using water jet technology to cut holes for bearing mounts and attachment of cross bracing. This provides a strong rigid frame and eliminates corrosion even with long intervals between operations.

## Proportional Tracking:

A paddle activated proportional control belt tracking system continuously centers the belts.



Stainless Steel Plate Frame

# A Leader in Solids Dewatering.

BDP Industries is an OEM supplier of solids dewatering equipment for several prestigious Fortune 500 companies. With a 40,000 sq. ft. manufacturing facility and the most hands on experience in the industry, BDP has evolved into one of the most modern and complete solids dewatering suppliers in the world.



BDP Industries produces a range of high quality products and services:

- Gravity Belt Thickeners
- Belt Presses
- Screw Presses
- Rotary Drum Concentrators
- Lime Stabilization Systems
- Polymer Systems
- Compost Turning Equipment
- Pulp & Paper Stock Thickeners
- Plate & Frame Presses
- Conveyors
- Process Control Panels
- Equipment Restoration
- On-Site Service
- Mobile Dewatering Demonstrations



P.O. Box 118  
 354 State Route 29  
 Greenwich, NY 12834  
 TEL: (518) 695-6851  
 FAX: (518) 695-5417

www.bdpindustries.com

© 2011 BDP Industries, Inc. This document is a general product presentation and is not a guarantee of any kind. All the information contained herein is subject to change without notice. Directions for use and safety will be given separately.

**Dimensions:** The model DDP is available in a single belt width: 0.9 meters (effective).

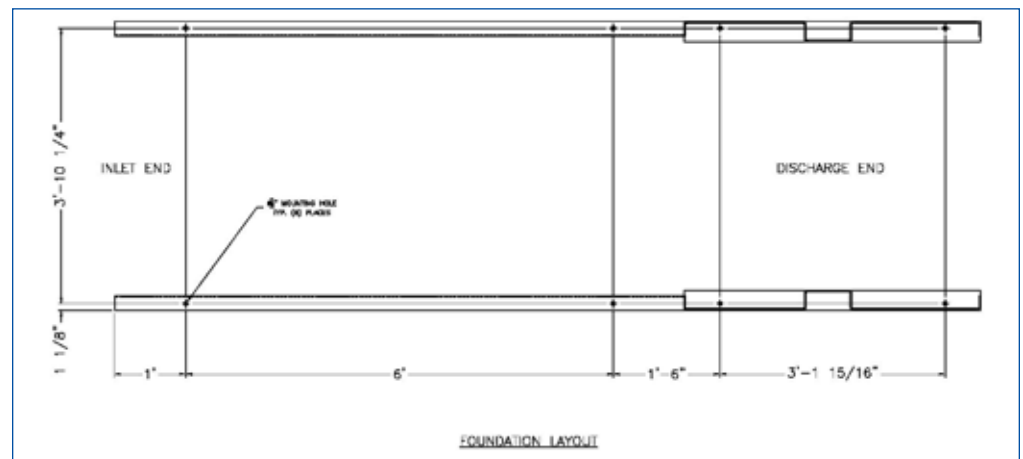
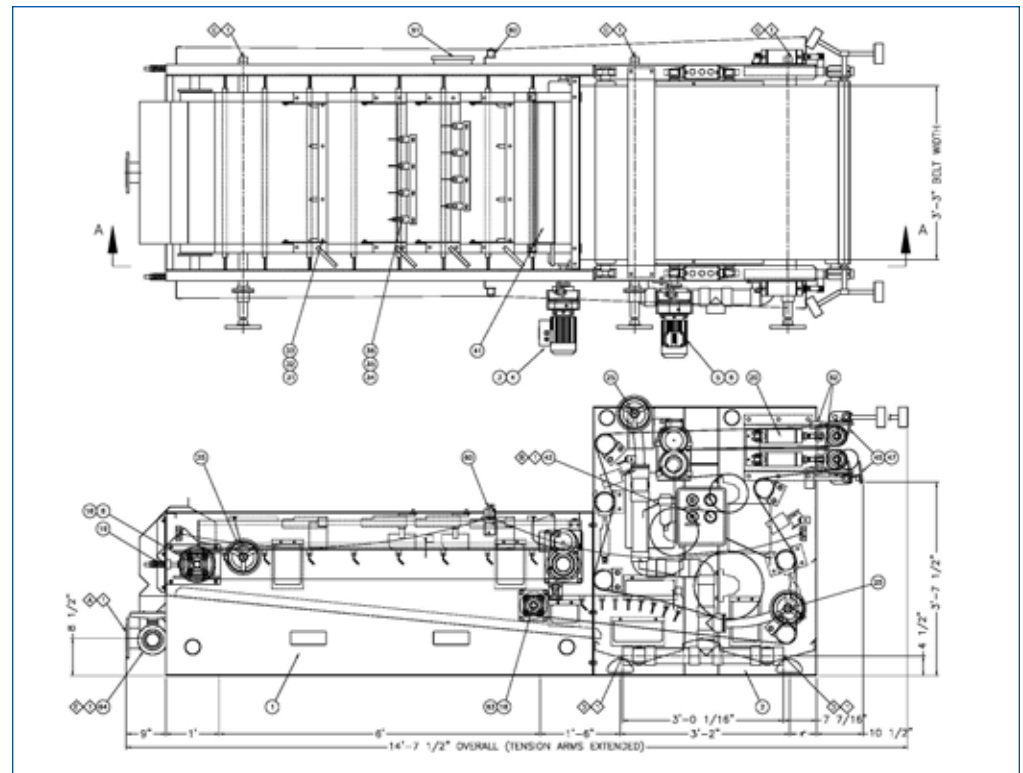

### DDP Machine Data

| Size | Belt Width<br>meters | Horsepower   |               | Dry Weight<br>lbs | Belt Wash |     |          |
|------|----------------------|--------------|---------------|-------------------|-----------|-----|----------|
|      |                      | Gravity zone | Pressure zone |                   | gpm       | psi | motor hp |
| 0.9  | 0.9                  | 1            | 1             | 7,000             | 44        | 120 | 3        |

Only one size is offered, this minimizes material waste and lowers manufacturing cost.

### Typical Performance Results

| Sludge Type            | Feed Consistency<br>wt % | Solid Loading<br>lbs/hr, m | Cake Dryness<br>wt % | Polymer Dosage<br>lbs/ton |
|------------------------|--------------------------|----------------------------|----------------------|---------------------------|
| Aerobically Digested   | 1 to 3                   | 350 to 550                 | 10 to 15             | 12 to 18                  |
| Waste Activated        | 1.7 to 1.5               | 350 to 550                 | 11 to 14             | 10 to 15                  |
| Anaerobically Digested | 2 to 5                   | 540 to 900                 | 12 to 17             | 8 to 12                   |
| Primary + WAS          | 3 to 5                   | 540 to 1100                | 12 to 18             | 6 to 10                   |
| Primary + RBC          | 3 to 5                   | 600 to 1200                | 13 to 19             | 10 to 12                  |
| Raw Primary            | 4 to 8                   | 1200 to 1800               | 21 to 26             | 3 to 5                    |
| SBR                    | 1 to 1.5                 | 300 to 500                 | 11 to 14             | 10 to 15                  |
| MBR                    | 0.8 to 1                 | 300 to 500                 | 11 to 14             | 10 to 15                  |