

# Biosolids Dewatering Options

## Designed for Small Plants

[www.bdpindustries.com](http://www.bdpindustries.com)



0.9 Meter DDP, Oakley, Utah WWTP



DSP Screw Press, Groton, NY WWTP



Dry granular discharge solids from the Screw Press

# Big performance in a small package...

The **Model 3012 DSP Screw Press and the DDP Belt Press** were developed with the smaller size wastewater treatment facility in mind. Benefits for both models include full stainless steel construction for excellent corrosion resistance, enclosed design for odor handling and control, unattended operation, and superior solids handling, all with a small footprint.

## DDP Belt Press

The **Model DDP Belt Press** incorporates a 3-belt design that will provide higher performance and flexibility over the competition.



## DDP Features

### **3-BELT DESIGN: Enhances capacity and cake solids.**

BDP uses a 3-belt design to increase performance. Standard 2-belt technology employed by most manufacturers forces a compromise in either throughput capacity or discharge cake solid concentration because belt speed for the gravity and pressure zones must be the same. Three belt technology used by BDP overcomes this limitation by allowing independent speed control in each zone.

In addition, significant improvements in feed distribution, the wedge zone, gradual pressure gradation, and the elimination of pooling and re-wetting in the pressure zone **MAXIMIZES PERFORMANCE.**

The unique low profile gravity zone, stainless steel plate frame, and stainless steel bearings provide ease of access and low maintenance cost.



Vertical Pressure Zone

### **FEED DISTRIBUTOR: Provides longer belt life.**

Slurry enters the feed box at floor level and then flows up and over the outlet weir uniformly spread across the full belt width.



Spiral Wedge

### **SPIRAL WEDGE: Improved cake solids.**

The support bars of the wedge zone are fabricated in a spiral curve layout that forces the top and bottom belts together placing pressure on the cake throughout the entire zone. The support bars also function as cross supports for the frame.

### **VERTICAL PRESSURE ZONE: Increased solids capacity and cake solids.**

The rolls in the pressure zone are arranged in a vertical configuration so that filtrate expressed at each roll falls into a diversion pan rather than an adjacent roll; eliminating rewetting of the cake. The first roll is perforated to enhance expression of filtrate.

### **STAINLESS STEEL PLATE FRAME: Maximizes corrosion resistance and makes cleaning easier.**

The frame is constructed from stainless steel plate, precision crafted using water jet technology to cut holes for bearing mounts and attachment of cross bracing. This provides a strong rigid frame and eliminates corrosion even with long intervals between operations.

### **PROPORTIONAL TRACKING:**

**Increased belt life.** A paddle activated proportional control belt tracking system continuously centers the belts.



Proportional Tracking

# two great options for the smaller facility.

## DSP Screw Press

The Model 3012 DSP Screw Press is the ideal choice for the plant with a low wash water requirement and/or the necessity to dewater material that may contain tramp material.

## Screw Press Features

**INDEPENDENT PRE-THICKENING WITH ROTARY DRUM THICKENER (RDT): Enhanced capacity and cake solids.** Independently controlled pre-thickening and dewatering pressure section allows significantly greater process optimization than possible when the two sections are coupled. Pre-thickening is accomplished by an Independent RDT. Because the RDT is a totally separate unit the size can be easily changed to provide the pre-thickening filtration area required for the application.



Independent Pre-Thickening

**SLOT SCREEN DESIGN: Prevents plugging, maximizes capacity.** Perforated plate or wedge wire limits the porosity of the filter surface to 1 mm diameter due to structural issues. The DSP Screw Press uses a unique in-house fabricated water jet slotted screen design to allowing maximum drainage. The slotted arrangement /configuration and special wedge cross section profile of each slot prevents solids loss with the filtrate while allowing for maximum drainage by not plugging or blinding.



Slot Screen Design

**FILTRATE RECYCLE: Significantly improves solids capture.** Filtrate from the end of the high pressure screw section is recycled back to the Rotary Drum Thickener section, thereby capturing solids that would normally be lost with the pressure section filtrate.

**REPLACEABLE FLIGHT: Lowers maintenance costs.** Competitors typically incorporate screw flights welded to the shaft. BDP's design has flights that are bolted to a base assembly



allowing the flights to be adjusted and easily replaced, thereby maintaining proper clearance between the flight tip and the slotted screen. This ensures optimum performance as it reduces thickness of the material that accumulates on the internal screen surface thereby maximizing filtrate drainage.

**TAPERED SCREW DESIGN: Highest cake solids in the industry.** A screw press functions by reducing the volume inside the perforated enclosure as the screw augers the cake toward the discharge. BDP Industries uses a tapered auger shaft. This creates a reduction in path length for the liquid to be expressed from the cake and causes a pressure force at right angle to the auger shaft and against the perforated drum. This reduces the tendency for plug formation and means higher pressures are possible or drier cake. Most manufacturers reduce the



Tapered Screw Design

distance between screw flights toward the discharge end. This method means that the path length for the liquid to be expressed from the cake stays constant and the pressure exerted on the cake is primarily along the axis of the screw flights. This axial pressure against the face of the screw flights increases the potential to cause the cake to turn with the screw. When this happens the cake is no longer being augered, causing what is referred to as plug formation.

**PRESSURE PLATE: Easy adjustment ensures desired cake solids.**

An adjustable pressure plate at the discharge of the screw allows maximization of the cake solids. The pressure plate utilizes three adjustment nuts to vary the pressure. This easy-to-operate design allows for simple pressure setting.



Pressure Plates

# A Leader in Solids Dewatering.

BDP Industries is an OEM supplier of solids dewatering equipment for several prestigious Fortune 500 companies. With a 40,000 sq. ft. manufacturing facility and the most hands on experience in the industry, BDP has evolved into one of the most modern and complete solids dewatering suppliers in the world.



BDP Industries produces a range of high quality products and services:

- Gravity Belt Thickeners
- Belt Presses
- Screw Presses
- Rotary Drum Concentrators
- Lime Stabilization Systems
- Polymer Systems
- Compost Turning Equipment
- Pulp & Paper Stock Thickeners
- Plate & Frame Presses
- Conveyors
- Process Control Panels
- Equipment Restoration
- On-Site Service
- Mobile Dewatering Demonstrations



P.O. Box 118  
 354 State Route 29  
 Greenwich, NY 12834  
 TEL: (518) 695-6851  
 FAX: (518) 695-5417

[www.bdpindustries.com](http://www.bdpindustries.com)

© 2011 BDP Industries, Inc. This document is a general product presentation and is not a guarantee of any kind. All the information contained herein is subject to change without notice. Directions for use and safety will be given separately.

**DDP Dimensions:** The model DDP is available in a single belt width: 0.9 meters (effective).

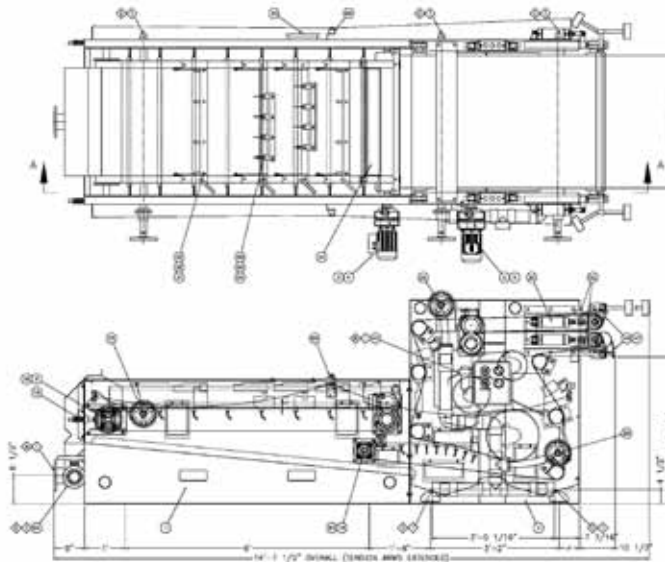

### Typical Performance Results – DDP

Sludge Type wt %	Feed Consistency lbs/hr, m	Solid Loading wt %	Cake Dryness lbs/ton	Polymer Dosage
Aerobically Digested	1 to 3	350 to 550	10 to 15	12 to 18
Waste Activated	1.5 to 1.7	350 to 550	11 to 14	10 to 15
Anaerobically Digested	2 to 5	540 to 900	12 to 17	8 to 12
Primary + WAS	3 to 5	540 to 1100	12 to 18	6 to 10
Primary + RBC	3 to 5	600 to 1200	13 to 19	10 to 12
Raw Primary	4 to 8	1200 to 1800	21 to 26	3 to 5
SBR	1 to 1.5	300 to 500	11 to 14	10 to 15
MBR	0.8 to 1	300 to 500	11 to 14	10 to 15

### Screw Press Dimensions

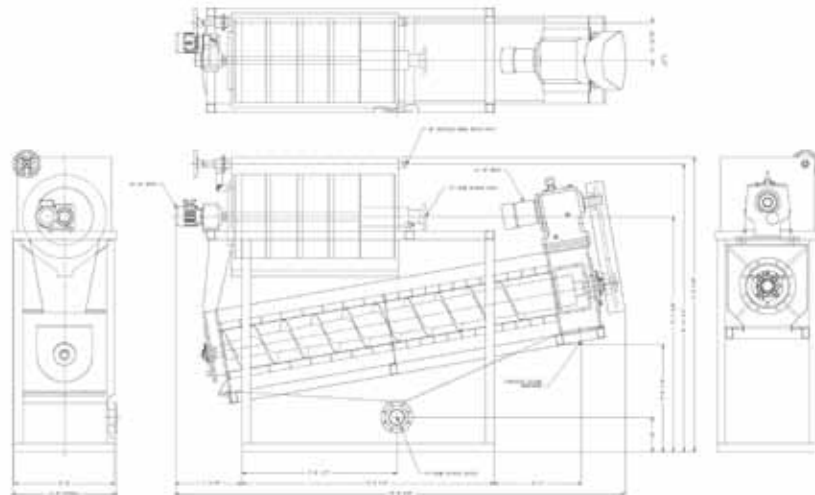

### Typical Performance Results – Screw Press

Sludge Type	Feed Consistency wt %	Solid Loading lbs/hr, m	Cake Dryness wt %	Polymer Dosage lbs/ton
Aerobically Digested	1 to 3	110 to 150	12 to 18	12 to 18
Waste Activated	1.5 to 1.7	110 to 150	12 to 18	12 to 18
Anaerobically Digested	2 to 5	130 to 170	15 to 20	9 to 11
Primary + WAS	3 to 5	150 to 180	15 to 22	6 to 10
Primary + RBC	3 to 5	160 to 200	15 to 23	11 to 15
Raw Primary	4 to 8	300 to 240	22 to 28	4 to 6
SBR	1 to 1.5	90 to 110	12 to 17	12 to 18
MBR	0.8 to 1	90 to 110	12 to 17	12 to 18