

H03x3 Belt Filter Press

www.bdpindustries.com

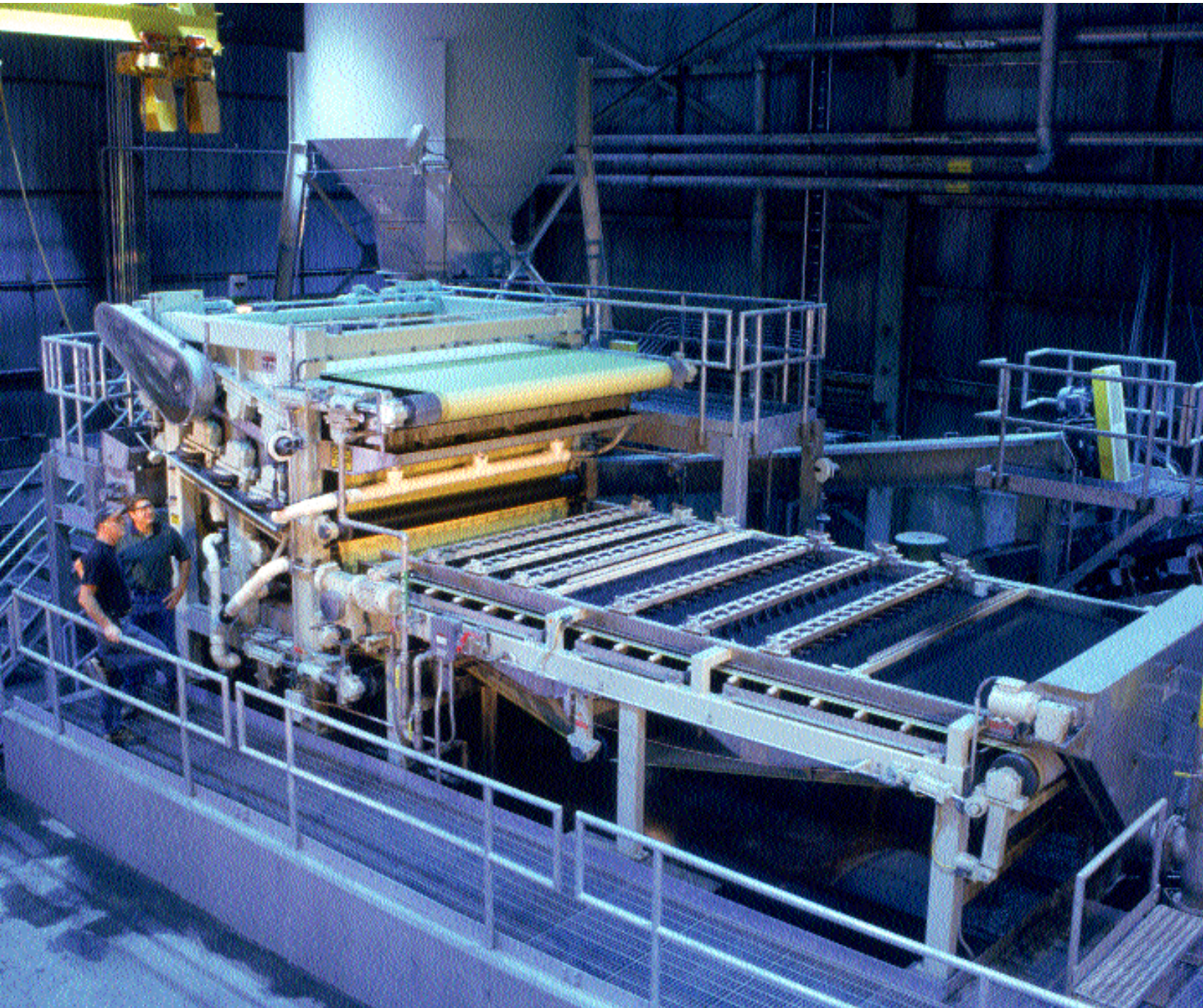

Industry Leader in Design and Manufacture of Filtration Equipment

The BDP HO3x3 Three-Belt Filter Press sets a new standard for belt filter press dewatering, with its separate GRAVITY and PRESSURE sections.

Tests show that the HO3x3 clearly outperforms other presses. Designed with *your* operators in mind, it is *the press for your pulp & paper sludge*.



Carl

Carl Fronhofer
President

HIGHLIGHTS

The HO3x3 is a dual-purpose machine. The Thickener section can be used alone to pre-thicken sludge. Or, two sections can be combined to thicken and dewater sludge.

Tests show that the gravity belt thickener boosts feed solids concentration to the pressure section by 2 to 10 times, allowing a steeper pressure gradient to be applied to the compression zone without risk of extrusion loss.

The HO3x3 provides hydraulic loading capacities that are in most cases more than double those of traditional presses. These features result in higher throughput and drier cakes — which mean lower costs for sludge handling and disposal.

HO3x3 BELT FILTER

1. Up-flow style flocculating feedbox with variable speed paddle wheel
2. Adjustable angle furrowing plows
3. 8' to 14' gravity drainage zone
4. Independent drainage and press section
5. Sludge spreader mechanism for uniform distribution
6. Adjustable wedge section
7. Non-rewetting perforated roll
8. High pressure nip section
9. Rack and pinion tensioning system
10. High discharge point

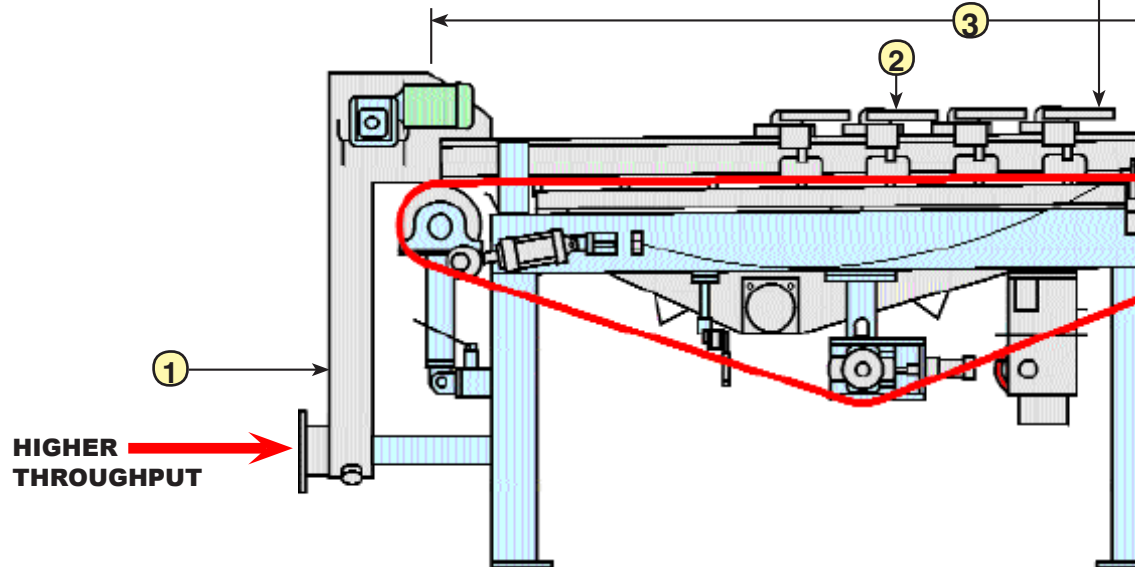

Gravity Section

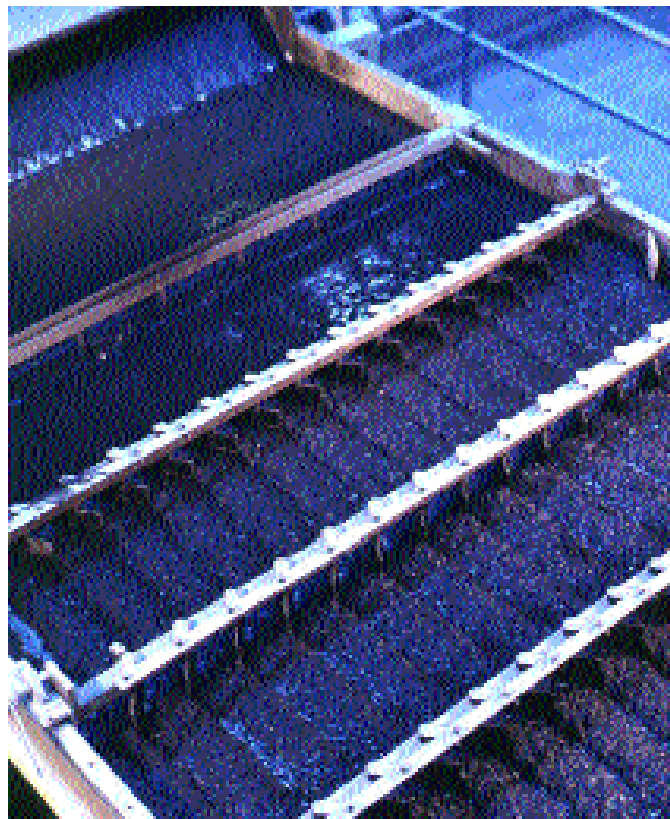

Independent Belt

Belt type and speed are varied independently from pressure section.

Maximum Gravity Dewatering

Hydraulic loading variations can be easily accommodated by adjusting belt speed independently.

Optimum Flocculation and Distribution

Upflow feedbox with variable speed paddle wheel provides even distribution of feed sludge before furrowing plows.

Adjustable Angle Plows

Adjustable plows to maximize drainage.

Ease of Operation and Maintenance

Floor level viewing with no catwalks or ladders.

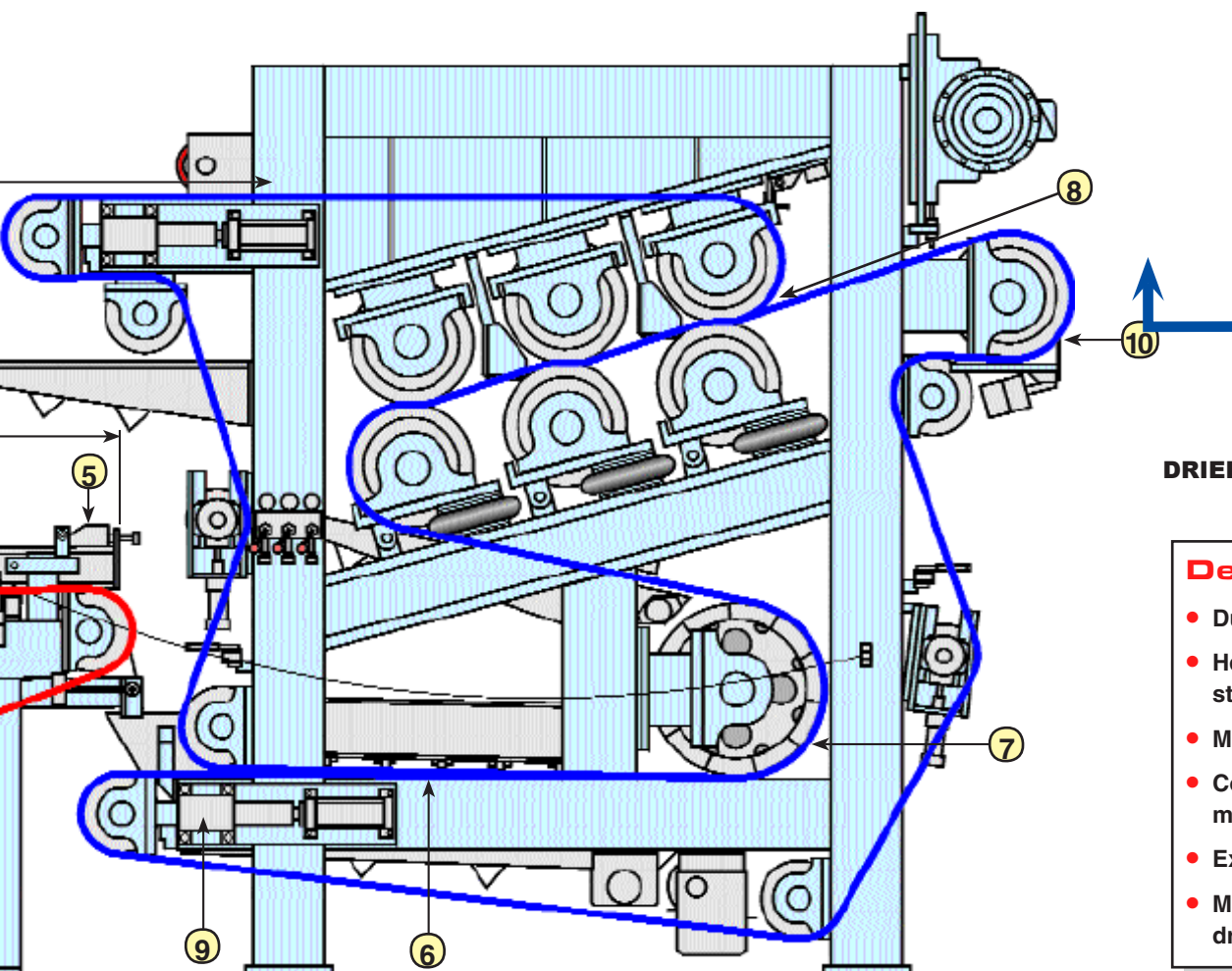

DRIER CAKE

Design Features

- Dual purpose operation
- Heavy duty tubular steel frame
- Machined bearing pads
- Corrosion-resistant materials and coatings
- Extended life bearings
- Maximum efficiency drainage system

How it works

In the past, when hydraulic loading rates varied, either throughput or final cake solids had to be sacrificed. Not so with the HO3x3. Gravity drainage is most effective when feed sludge is applied thin, requiring the belt to operate at higher speeds. Pressure sections achieve maximum cake dryness when operated slowly, since slower belt speeds produce longer retention times under pressure.

The HO3x3 enables the gravity thickening belt speed to vary in conjunction with slower pressure section speed - resulting in maximum effectiveness for both stages. Load variations can be easily accommodated by adjusting the thickener belt speed to maximize sludge thickening prior to the pressure section. The end result is maximum dewatering of your pulp & paper sludge.

Vertical Pressure Section

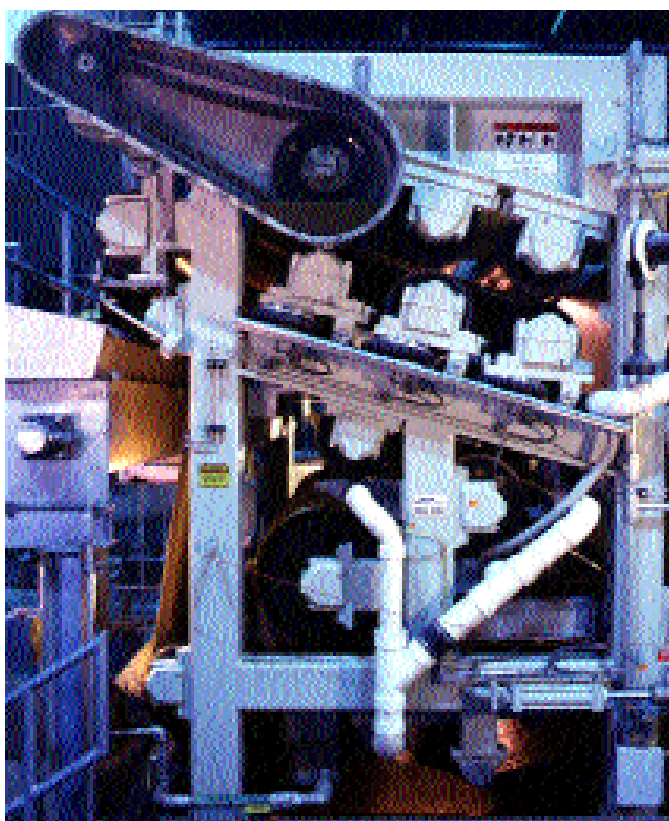

Optimum Pressure

Hydraulic tensioning provides 40 PLI belt tensioning through a wedge section and nip section.

Independent Belt

Belt type and speed are varied independently from gravity section.

Maximum Dewatering

Adjustable upper and lower supported wedge section, two S-wrap rolls including an internally baffled perforated roll, and three adjustable high pressure nip rolls provide flexibility and maximum performance to obtain optimal dryness.

Simplified Conveying

High sludge discharge point reduces or eliminates need for conveyor.

A Leader in Solids Dewatering.

BDP Industries is an OEM supplier of solids dewatering equipment for several prestigious Fortune 500 companies. With a 40,000 sq. ft. manufacturing facility and the most hands on experience in the industry, BDP has evolved into one of the most modern and complete solids dewatering suppliers in the world.



BDP Industries produces a range of high quality products and services:

- Gravity Belt Thickeners
- Belt Presses
- Screw Presses
- Rotary Drum Concentrators
- Lime Stabilization Systems
- Polymer Systems
- Compost Turning Equipment
- Pulp & Paper Stock Thickeners
- Plate & Frame Presses
- Conveyors
- Process Control Panels
- Equipment Restoration
- On-Site Service
- Mobile Dewatering Demonstrations



P.O. Box 118
354 State Route 29
Greenwich, NY 12834
TEL: (518) 695-6851
FAX: (518) 695-5417

www.bdpindustries.com

© 2011 BDP Industries, Inc. This document is a general product presentation and is not a guarantee of any kind. All the information contained herein is subject to change without notice. Directions for use and safety will be given separately.

PERFORMANCE TABLE

Typical Performance Results Sludge Dewatering Spectrum for HO3x3

SLUDGE TYPE	FEED CONSISTENCY	PROCESSING RATES	CAKE DRYNESS	POLYMER CONSUMPTION*
Primary	0.5 - 8%	2000 - 4000 lbs/hr/M	35 - 50%	0 - 6 lbs/dt

* Polymer consumption is based on 100 percent active ingredients

Because influents, processes and operation vary greatly, processing results have a wide range. The ratio of blends will also have an impact on dewatering. The above represent the ranges that might be expected.

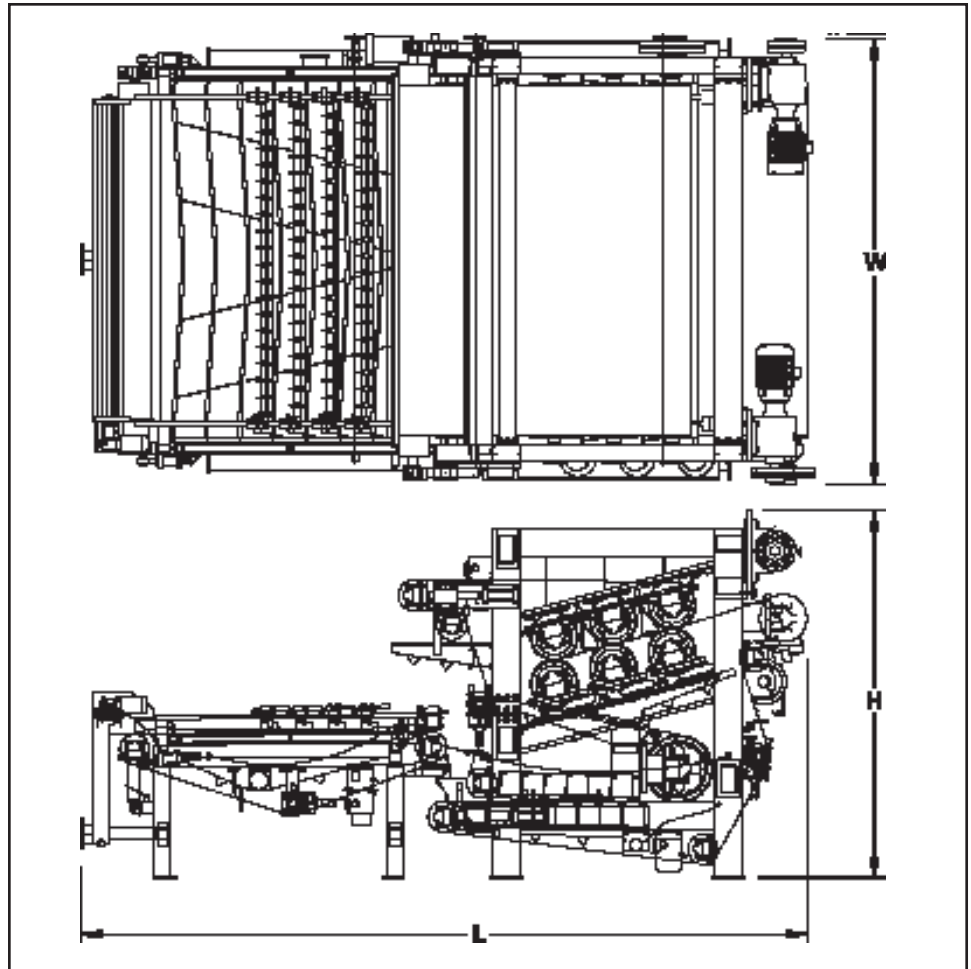

SPECIFICATION TABLE

BDP HO3x3 Belt Filter Press Machine Data

SIZE (m)	OVERALL APPROX. DIMENSIONS inches (mm)			OPERATING WEIGHT lbs (kg)	BELT WIDTH m
	LENGTH*	WIDTH	HEIGHT		
0.75	256 (6,502)	70 (1,778)	98 (2,489)	11,000 (5,000)	0.9
1.0	256 (6,502)	80 (2,032)	118 (2,997)	18,500 (8,400)	1.2
1.5	256 (6,502)	100 (2,540)	118 (2,997)	25,000 (11,400)	1.7
2.0	258 (6,553)	120 (3,048)	120 (3,048)	33,000 (15,000)	2.2
2.5	260 (6,604)	140 (3,556)	126 (3,200)	46,000 (20,000)	2.7
3.0	262 (6,655)	164 (4,165)	132 (3,353)	56,000 (25,400)	3.2

Custom sizes and designs available upon request

* Note: Length is based on 8 ft gravity deck